



A-UNIQUE

ASIA UNIQUE LED LIGHTING CO., LTD

Maintained Emergency LED Batten

AU02-BAT Series

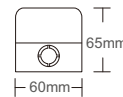
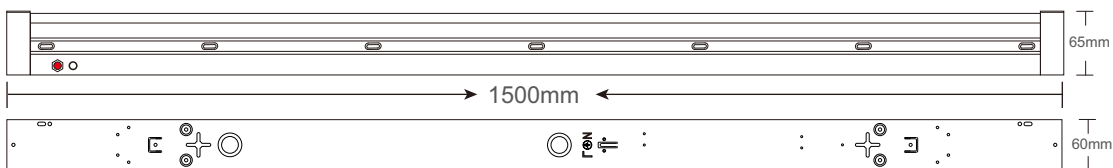
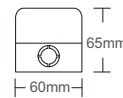
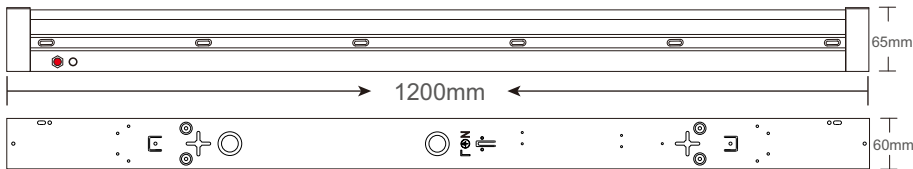
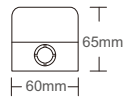
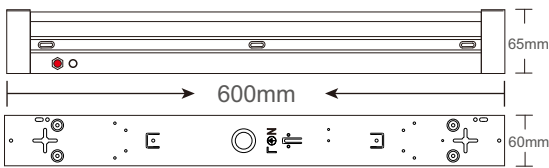
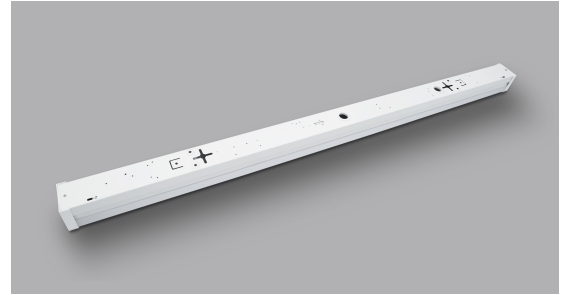



General Features:

- Wire from back or two ends, with big entry hole;
- Big Terminal Block or Quick play & plug connector, easy installation
- LED Replaceable board, very even light distribution
- Suspension strap attached to the lamp & base part, makes installation easier
- Can be Surface Mounted or Suspended
- Can be linked one to another, end by end, without gap
- CE, Rohs, SAA, C-tick & AS/NZ 2293.3 Approved
- LiFePO4 Battery adopted, 3.5W run 3 hours
- 3 years warranty for whole lamp

Technical Specifications

Model No.	AU02-BAT18W2FXX-ME3.5W	AU02-BAT36W4FXX-ME3.5W	AU02-BAT50W5FXX-ME3.5W
Dimension(mm)	600*60*65	1200*60*65	1500*60*65
Cutout(mm)	/	/	/
Wattage(w)	Running Ordinary	18W	36W
	Emergency Mode	3.5W run 3 hours	3.5W run 3 hours
Input Voltage(v)	AC220~240V		
Light Source	SMD2835		
SDCM	<6		
CCT(K)	1 CCT	2700K/3000K/4000K/5000K/5700K/6500K	
	3 CCT	3000K-4000K-5000K or 3000K-4000K-5700K or 4000K-5000K-5700K	
Luminous Flux (lm)±5%	1890-2070	3780-4140	5250-5750
CRI	>80Ra		
Beam Angle(°)	120°		
Dimming option	Available		
Sensor option	Available		
Emergency Kits	Maintained Emergency		
Battery	LiFePO4		
Protection Class	Class I		
Degree of protection(IP)	IP20		
Impact Resistance(IK)	IK08		
Material	Base	Iron	
	Heatsink	PC	
	Diffuser	PC	
L70	>54000Hrs		
Glow Wire Test(°C)	650°C		
Operation Temp.(°C)	-20~ 45°C		
Installation	Surface Mounted / Suspended		
Certificates	CE, Rohs, SAA & C-tick		
Warranty	3 Years		

Packing information

Model Number	Weight/Luminaire (kg)	QTY/BOX (pcs)	Inner Box Size (mm)	Weight/Box (kg)	QTY/CTN (pcs)	Carton Size (cm)	Weight/CTN (kg)	QTY/20GP (PCS)	QTY/40GP (PCS)	QTY/40HQ (PCS)
AU02-BAT18W2FXX-ME3.5W	1.05	1	615*70*75	1.15	8	62*29.5*17	9.8	7232	15152	17176
AU02-BAT36W4FXX-ME3.5W	1.85	1	1215*70*75	2	6	122*22.5*17	12.7	3222	7332	8412
AU02-BAT50W5FXX-ME3.5W	2.25	1	1515*70*75	2.5	6	152*22.5*17	16	2730	5928	6768

Before installation, please read the instructions completely and carefully.

Wiring Diagram

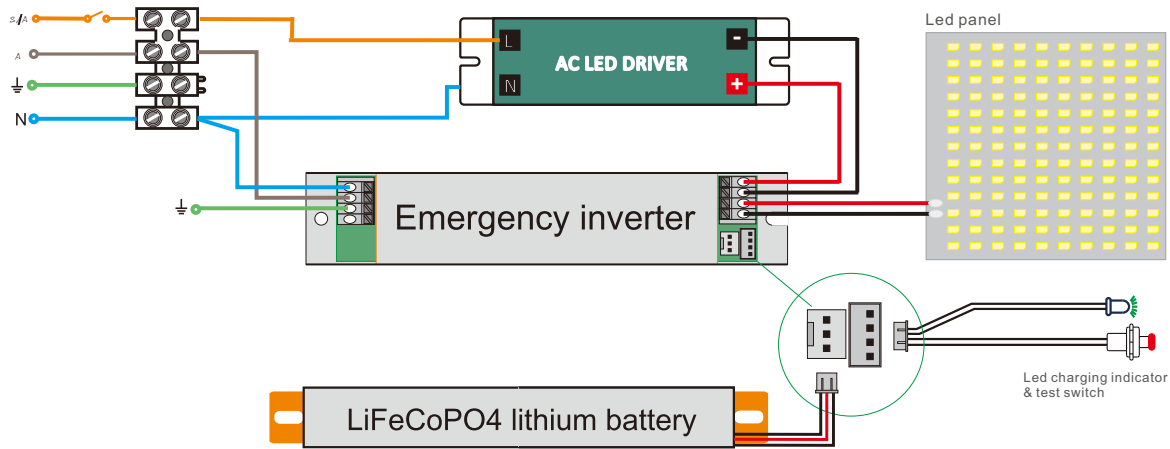

Testing

When luminaire is permanently connected to mains supply, allow the luminaire to fully charge for 24 hours.
Conduct following tests once the battery has fully charged:

Test 1:

A commissioning discharge test must be carried out once the luminaire is connected to mains supply.

The emergency luminaire must remain illuminated for at least 2 hours after disconnection from the mains power.

NOTE: The luminaire works on standard power when connected to mains supply and switches to 3.5W power during emergency mode operation.

Test 2:

Subsequent tests, performed every 6 months, require the luminaire to successfully operate in emergency mode for 90mins.

NOTE: A record shall be maintained of all the discharge tests performed on site at all times.

Test Switch and LED Indicator:

The Test Switch and LED indicator on the luminaire provide an indication of the status of the luminaire during testing and normal operation

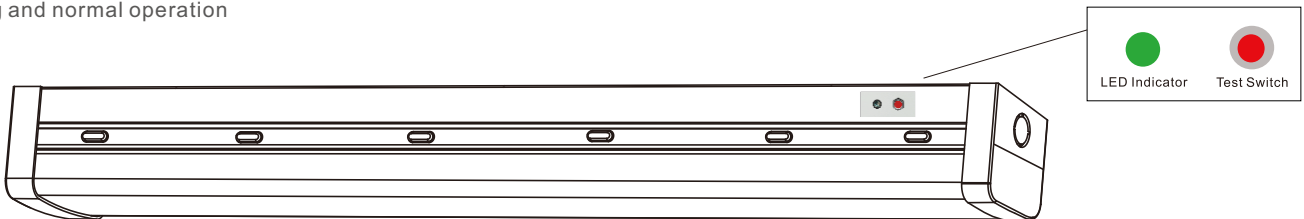

Test Switch&LED indicator	ON	OFF
<p>LED Indicator Test Switch</p>	<ul style="list-style-type: none"> • Depress the test switch-luminaire will operate in Emergency mode • LED indicator will be off during Emergency mode 	<ul style="list-style-type: none"> • On releasing the Test switch the luminaire will automatically connect to mains supply • LED indicator will illuminate
<p>LED Indicator Test Switch</p>	<ul style="list-style-type: none"> • Luminaire is working on mains supply 	<ul style="list-style-type: none"> • Luminaire is working in Emergency mode • Luminaire has malfunctioned

NOTE: * Self-test option is available

* It is recommended to disconnect the battery before storage or delivery

* Battery should be charged once in six months in order to keep it in initial performance

Installation Instructions

Step 1:

Turn off the power supply, slide the end caps, remove the LED diffuser part from the base housing

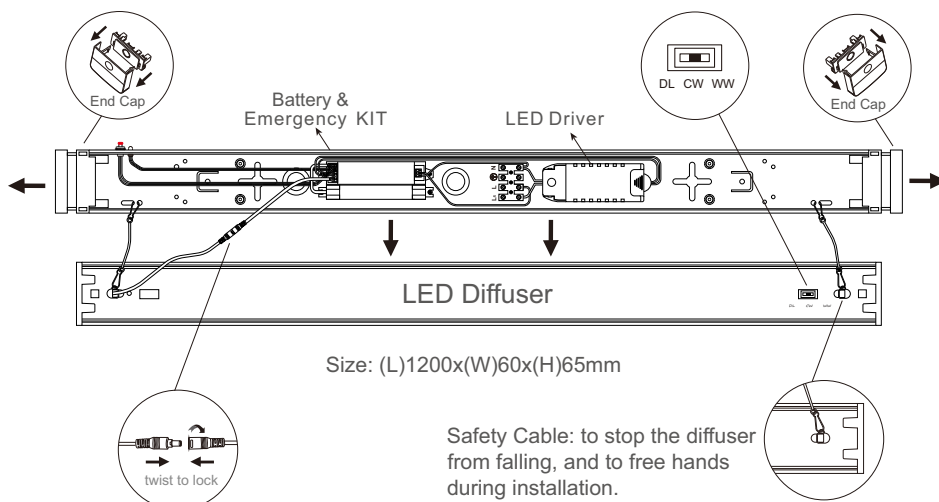

Step 2: Mount the fitting onto ceiling with wall plugs and screws

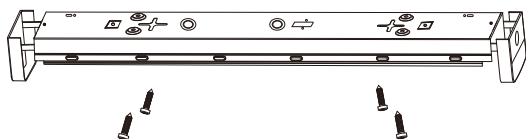

Surface Mounted

Step 2: Secure the mounting bracket to the steel cable

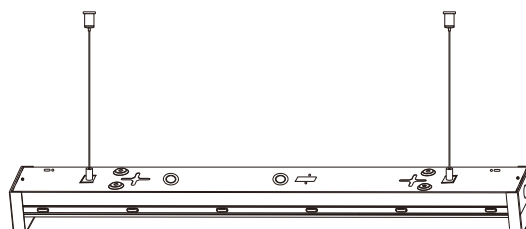

Suspended Mounted

Step 3: Wire the cable into the terminal block through the cable entry hole Insert connector between the base and diffuser; Assemble the diffuser back to the base and also the two caps.

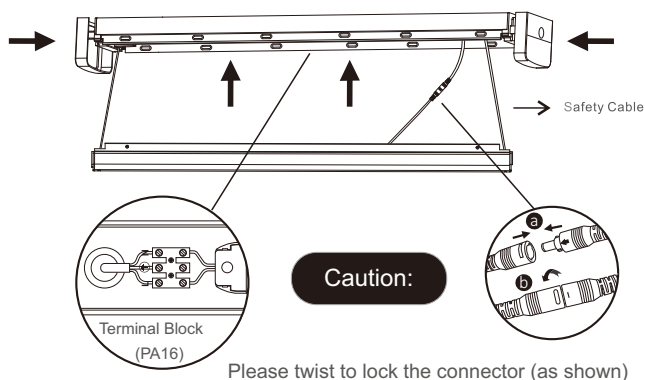

Step 4: Turn on the power supply to ensure the luminaire is working properly.

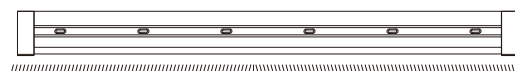

Packing List (each inner box)

LED Batten	1piece
Screw	4pcs
Wall Plug	4pcs

Please Note:

- * Turn off and isolate the electrical supply before connecting this fitting to the building wires.
- * Must be installed, or connected by licenced electrician.
- * The Luminaires are intended for indoor use only.

Applications:

- Warehouses
- Supermarkets
- Shopping Malls
- Office Buildings
- Workshops
- Car Parks