



A-UNIQUE

# ASIA UNIQUE LED LIGHTING CO., LTD

## STORM-AU04 LED Tri Proof Light-Tri Watt

## AU04-Tri-Proof Series

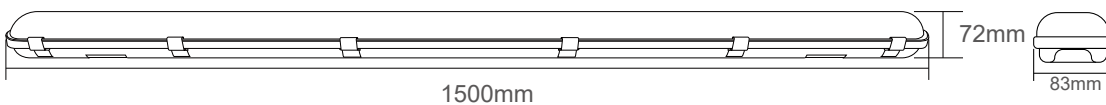
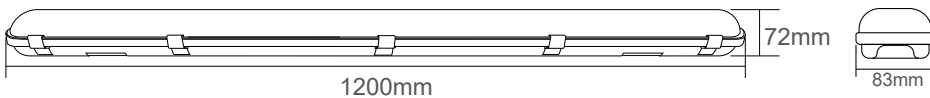
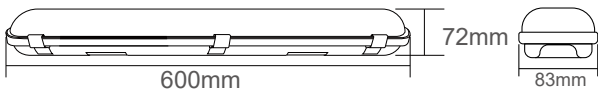
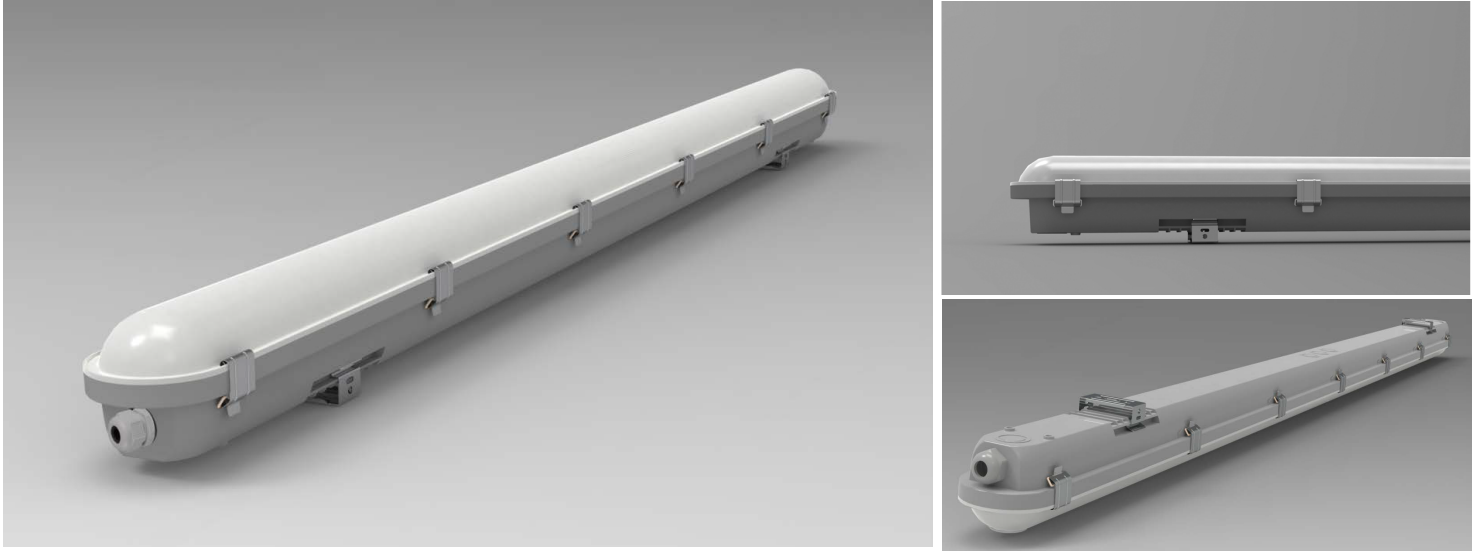

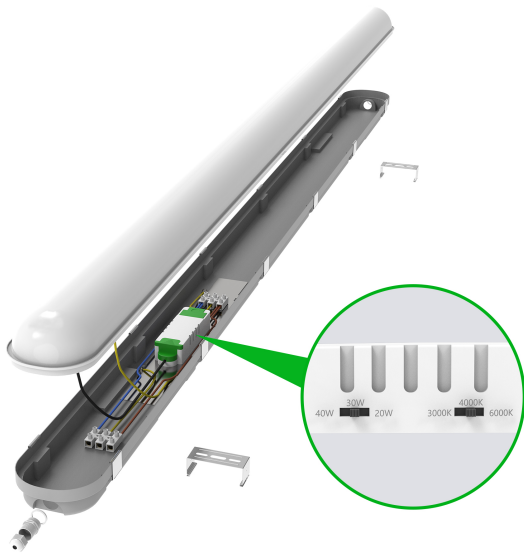

CCT & wattage switches on the driver

## General Features:

- Tri-wattage selectable by dip switch before installation
- Tri-color selectable by dip switch available
- IP65 - Waterproof, Dustproof, Moisture-proof
- High Lumen Efficiency 150LM/W Max
- Flicker free driver
- Full PCB board and the diffuser is a whole part, no need to take the PCB apart but wire directly, much easier than the normal design
- Cables can be from the back or the two ends of the light, easy wiring
- Easy clips, one step assembly
- With Safety cables, free your hands during the installation
- Can be Surface Mount or Suspension Mount
- Can be linked from one to another
- CE, RoHS, SAA & C-tick approved
- Sensor & Emergency versions available
- Triac Dimming, 0-10V Dimming & Dali Dimming available

## Technical Specifications

Model No.	AU04-TRIP101520W2FXX	AU04-TRIP203036W4FXX	AU04-TRIP203040W5FXX
Dimension(mm)	600*83*72	1200*83*72	1500*83*72
Cutout(mm)	/	/	/
Wattage(w)	10W-15W-20W	20W-30W-36W	20W-30W-40W
Input Voltage(v)	AC200~240V		
Light Source	SMD2835		
SDCM	<6		
CCT(K)	2700K/3000K/4000K/5000K/5700K/6500K 3000K-4000K-5000K or 3000K-4000K-5700K or 4000K-5000K-5700K		
CRI	>80		
Lumen (lm)±5%	130LM/W	130LM/W	130LM/W
Flicker free	Available		
Beam Angle(°)	120°		
Dimming option	Non-dimmable, Flicker Free		
Sensor option	Available		
Emergency Kits	Available		
Protection Class	Class I		
Degree of protection(IP)	IP65		
Impact Resistance(IK)	IK08		
Material	Brackets	Stainless steel	
	Heatsink	Aluminum	
	Diffuser	PC	
L70	54000Hrs		
Glow Wire Test(°C)	650°C		
Operation Temp.(°C)	-20~ 45°C		
Installation	Surface Mount / Suspension Mount		
Certificates	CE, Rohs, SAA & C-tick		
Warranty	3 Years		

## Packing information

Model Number	Weight/Luminaire (kg)	QTY/BOX (pcs)	Inner Box Size (mm)	Weight/Box (kg)	QTY/CTN (pcs)	Carton Size (cm)	Weight/CTN (kg)	QTY/20GP (PCS)	QTY/40GP (PCS)	QTY/40HP (PCS)
AU04-TRIP101520W2FXX	1.10	1	650*90*80	1.20	15	67*29*43	19	4437	9144	10287
AU04-TRIP203036W4FXX	1.70	1	1250*90*80	1.90	9	127*29*26	18	2232	4689	5364
AU04-TRIP203040W5FXX	1.90	1	1550*90*80	2.15	9	157*29*26	20	1800	3789	4311

# Installation Instructions

1. Drill holes and insert plastic dowel into the holes, fix the mounting bracket with provided screws.

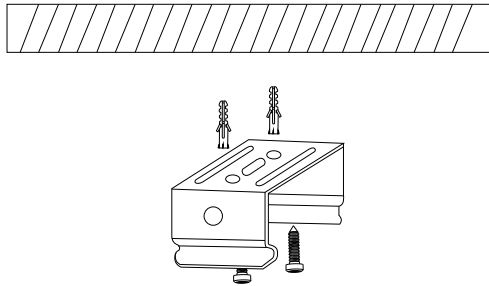

2. Open the clips with screw driver.

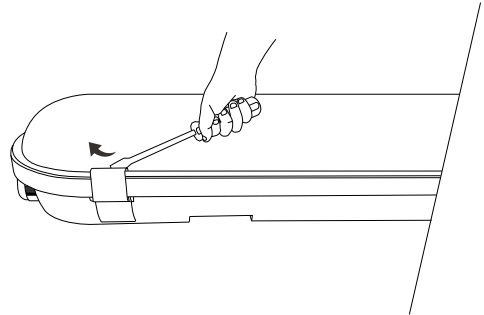

3. Remove the cover from the housing base

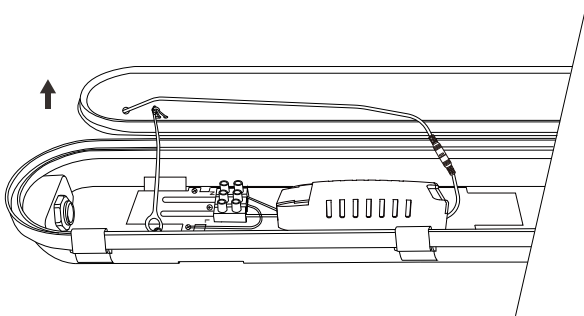

4. Loosen the cable gland and insert the power cable through the cable gland.

Select the required wattage & CCT via DIP Switch

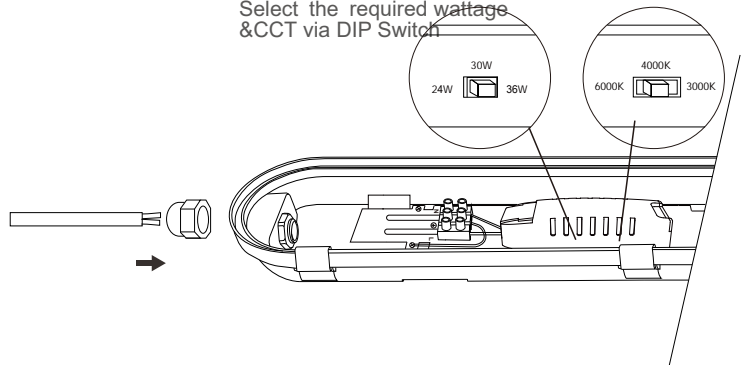

5. Connect the power cable to the driver and tighten the cable gland.

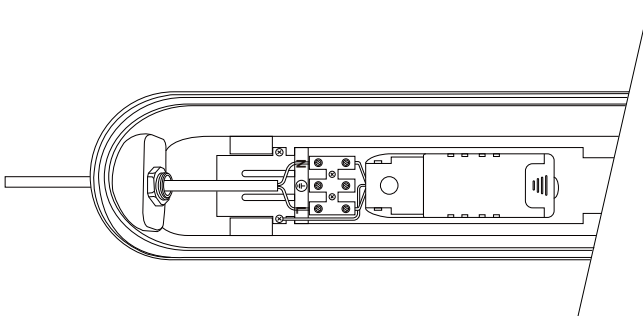

6. Reattach the cover and fasten the clips

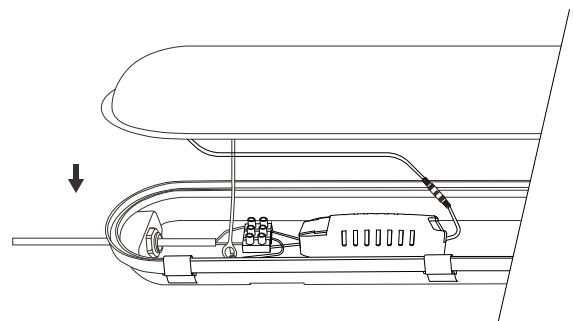

7. Mount the fixture on the ceiling / wall

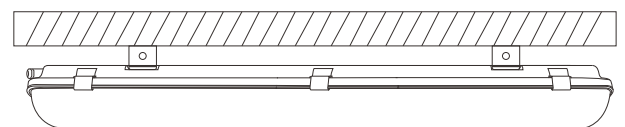
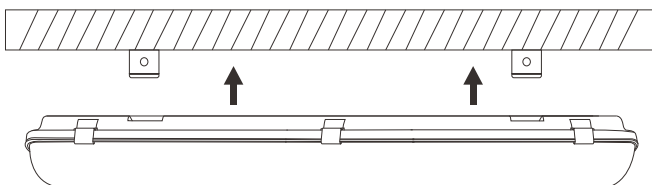

## Please Note:

- \*Product must be installed by licensed electrician.
- \*Disconnect or turn off the power before installation.
- \*Verify the supply Voltage is the same as rated luminaire voltage.

### Packing List (each inner box)

Tri-proof light	1pcs
Screw	6pcs
Brackets	2pcs
Connector	1pcs
Clip used to fix the cables	1pcs

## Applications:

- Parking lots
- Warehouses
- Factories
- Tunnels
- basements
- Lofts
- Balconies
- Car washing stations

## Installation caution

- Product must be installed by licensed electrician.
- Disconnect or turn off the power before installation.
- Verify the supply Voltage is the same as rated luminaire voltage.

## Application:

