



A-UNIQUE

# ASIA UNIQUE LED LIGHTING CO., LTD

## STORM AU02 LED Tri Proof Light -Tri Watt

## AU02-TRIP Series

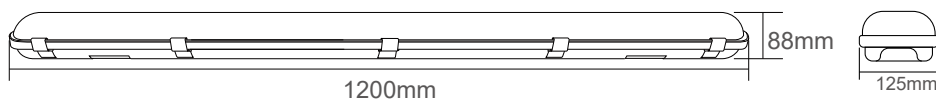
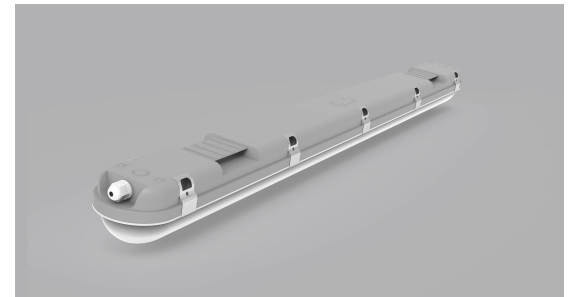
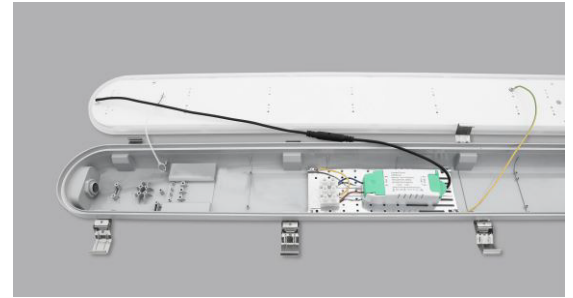

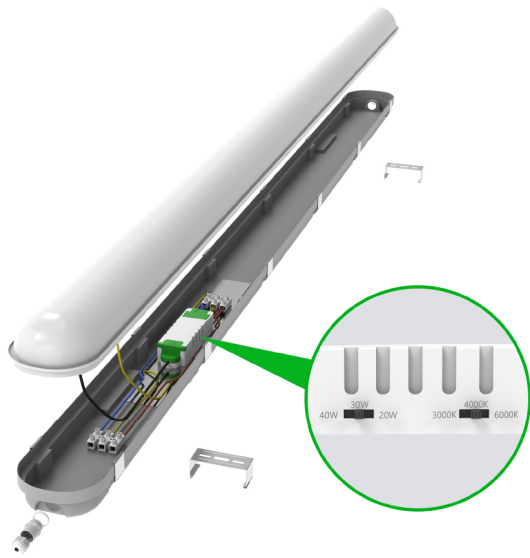

CCT & wattage switches on the driver

## General Features:

- **Tri-wattage selectable by dip switch before installation**
- Tri-color selectable by dip switch available
- IP65 - Waterproof, Dustproof, Moisture-proof
- High lumen efficiency - up to 150LM/W
- Flicker free driver
- Full PCB board and the diffuser is a whole part, no need to take the PCB apart but wire directly, much easier than the normal design
- Cables can be from the back or the two ends of the light, easy wiring
- Easy clips, one step assembly
- With Safety cables, free your hands during the installation
- Can be Surface Mounted or Suspended
- Can be linked one to another
- CE, RoHS, SAA & C-tick approved
- Sensor & Emergency versions available
- Triac Dimming, 1-10V Dimming & Dali Dimming available

## Technical Specifications

Model No.	AU02-TRIP101520W2FXX	AU02-TRIP203036W4FXX	AU02-TRIP203040W5FXX
Dimension(mm)	600*125*88	1200*125*88	1500*125*88
Cutout(mm)	/	/	/
Wattage(w)	10W-15W-20W	20W-30W-36W	20W-30W-40W
Input Voltage(v)	AC200~240V		
Light Source	SMD2835		
SDCM	<6		
CCT(K)	2700K/3000K/4000K/5000K/5700K/6500K 3000K-4000K-5000K or 3000K-4000K-5700K or 4000K-5000K-5700K		
CRI	>80		
Lumen (lm)±5%	1250lm-1875lm-2500ml	2500lm-3750lm-5000ml	2500lm-3750lm-5000ml
Flicker free	Available		
Beam Angle(°)	120°		
Dimming option	Non-dimmable, Flicker Free		
Sensor option	Available		
Emergency Kits	Available		
Protection Class	Class I		
Degree of protection(IP)	IP65		
Impact Resistance(IK)	IK08		
Material	Brackets	Stainless steel	
	Heatsink	Aluminum	
	Diffuser	PC	
L70	54000Hrs		
Glow Wire Test(°C)	650°C		
Operation Temp.(°C)	-20~ 45°C		
Installation	Surface Mounted / Suspended		
Certificates	CE, Rohs, SAA & C-tick		
Warranty	3 Years		

## Packing information

Model Number	Weight/Luminaire (kg)	QTY/BOX (pcs)	Inner Box Size (mm)	Weight/Box (kg)	QTY/CTN (pcs)	Carton Size (cm)	Weight/CTN (kg)	QTY/20GP (PCS)	QTY/40GP (PCS)	QTY/40HP (PCS)
AU02-TRIP101520W2FXX	1.30	1	660*130*90	1.40	6	68*28*31	9.0	3144	6528	7386
AU02-TRIP203036W4FXX	2.00	1	1260*130*90	2.30	6	128*28*31	15.0	1536	3124	3792
AU02-TRIP203040W5FXX	2.30	1	1560*130*90	2.70	6	158*28*31	17.2	1260	2622	2976

# Installation Instructions

1. Drill holes and insert plastic dowel into the holes, fix the mounting bracket with provided screws.

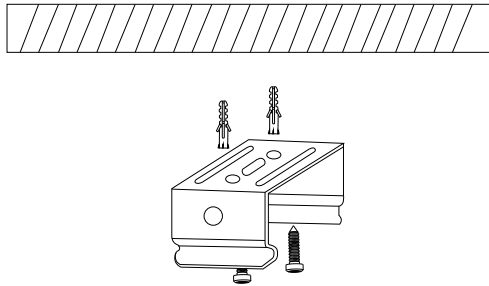

2. Open the clips with screw driver.

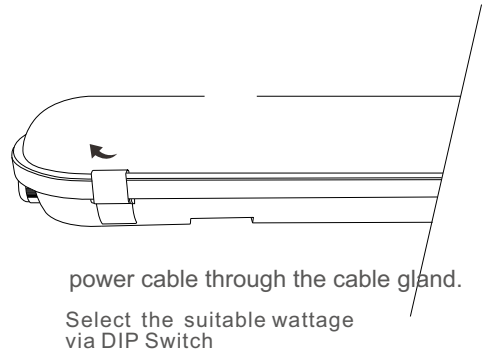

3. Remove the cover from the housing base

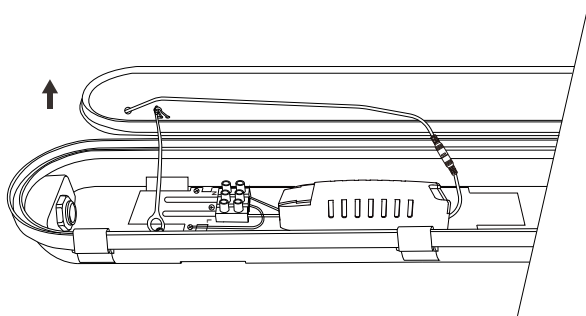

4. Loosen the cable gland and insert the

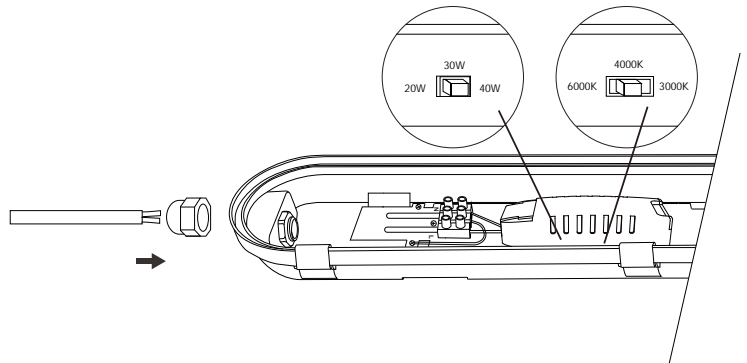

5. Connect the power cable to the driver and tighten the cable gland.

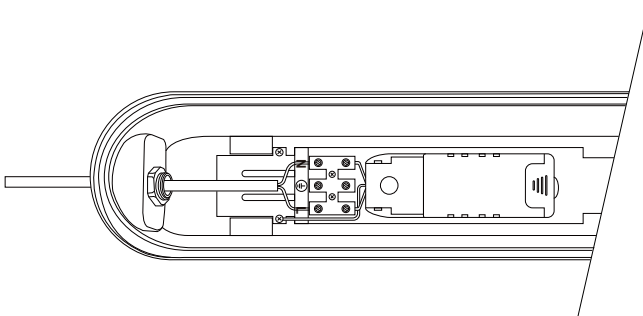

6. Reattach the cover and fasten the clip

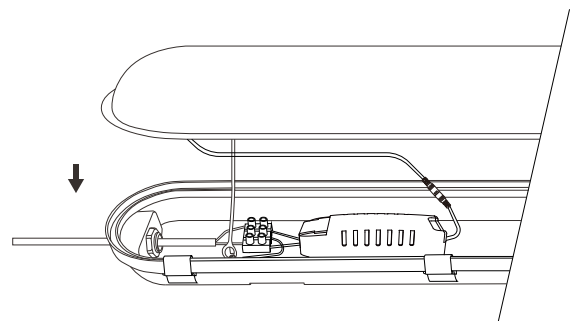

7. Mount the fixture on the ceiling / wall

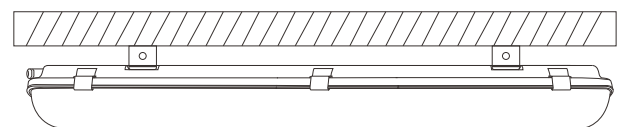
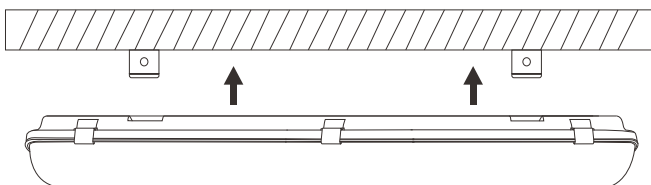

## Please Note:

- \*Product must be installed by licensed electrician.
- \*Disconnect or turn off the power before installation.
- \*Verify the supply Voltage is the same as rated luminaire voltage.

### Packing List (each inner box)

Tri-proof light	1pcs
Screw	4pcs
Brackets	2pcs

## Applications:

- Parking lots
- Warehouses
- Factories
- Tunnels
- basements
- Lofts
- balcony
- Car washing station

## Installation caution

- Product must be installed by licensed electrician.
- Disconnect or turn off the power before installation.
- Verify the supply Voltage is the same as rated luminaire voltage.

## Application:

