



A-UNIQUE

# ASIA UNIQUE LED LIGHTING CO., LTD

## NOVA LED Batten- Tri Power & 3CCT

## AU03-BAT Series

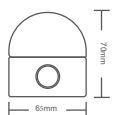
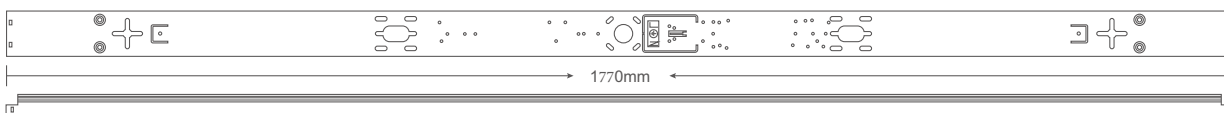
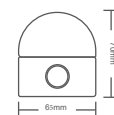
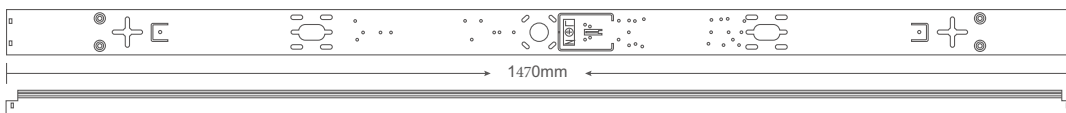
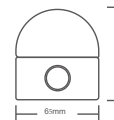
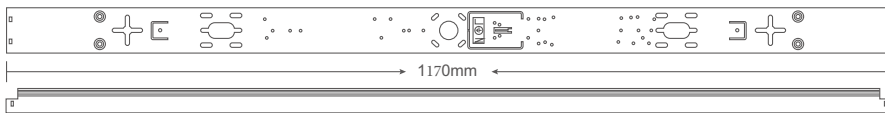
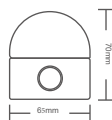
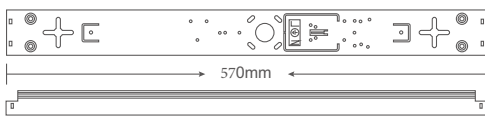
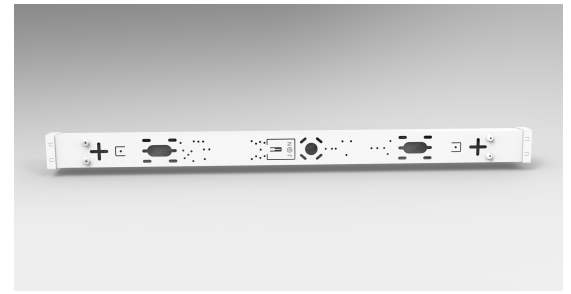



## General Features:

- Tri-wattage selectable by DIP switch
- Wire from back or two ends, with big entry hole;
- Big Terminal Block or Quick play & plug connector, easy installation
- LED Replaceable board, very even light distribution
- Suspension strap attached to the lamp & base part, makes installation easier
- Can be Surface Mounted or Suspended
- Can be linked one to another, end by end, without gap
- CE, Rohs, SAA & C-tick approved
- Tri-color, Sensor & Emergency versions are available
- Triac Dimming, 1-10V Dimming & Dali Dimming available

## Technical Specifications

Model No.	AU03-BAT101520W2F3C	AU03-BAT203036W4F3C	AU03-BAT203040W4F3C
Dimension(mm)	600*60*70	1200*60*70	1500*60*70
Cutout(mm)	/	/	/
Wattage(w)	10W-15W-20W	20W-30W-36W	20W-30W-40W
Input Voltage(v)	AC220~240V		
Light Source	SMD2835		
SDCM	<6		
CCT(K)	1 CCT	2700K/3000K/4000K/5000K/5700K/6500K	
	3 CCT	3000K-4000K-5000K or 3000K-4000K-5700K or 4000K-5000K-5700K	
Luminous Flux (lm)±5%	1150lm-2800lm	2400lm-5040lm	2300lm-5600lm
CRI	>80Ra		
Beam Angle(°)	120		
Dimming option	Available		
Sensor option	Available		
Emergency Kits	Available		
Protection Class	Class I		
Degree of protection(IP)	IP20		
Impact Resistance(IK)	IK08		
Material	Base	Iron	
	Heatsink	Iron	
	Diffuser	PC	
L70	54000hrs		
Glow Wire Test(°C)	650°C		
Operation Temp.(°C)	-20~ 45°C		
Installation	Surface Mounted / Suspended		
Certificates	CE, Rohs, SAA & C-tick		
Warranty	3 Years		

## Packing information

Model Number	Weight/Luminaire (kg)	QTY/BOX (pcs)	Inner Box Size (mm)	Weight/Box (kg)	QTY/CTN (pcs)	Carton Size (cm)	Weight/CTN (kg)	QTY/20GP (PCS)	QTY/40GP (PCS)	QTY/40HQ (PCS)
AU03-BAT101520W2F3C	0.80	1	615*70*75	0.9	8	62*29.5*17	7.9	7232	15152	17176
AU03-BAT203036W4F3C	1.60	1	1215*70*75	1.8	6	122*22.5*17	11.3	3222	7332	8412
AU03-BAT203040W4F3C	2.00	1	1515*70*75	2.35	6	152*22.5*17	15.0	2730	5928	6768

# Installation Instructions

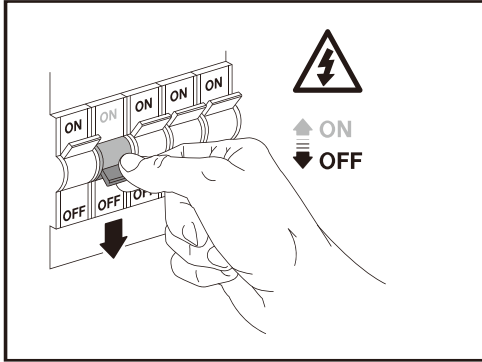

1

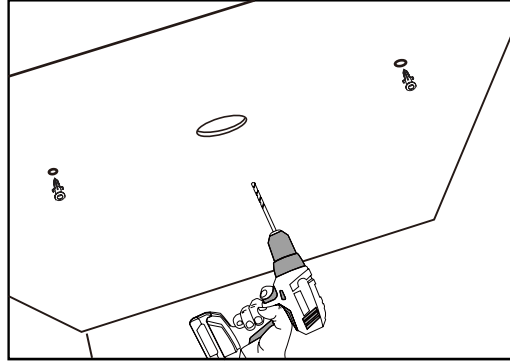

2

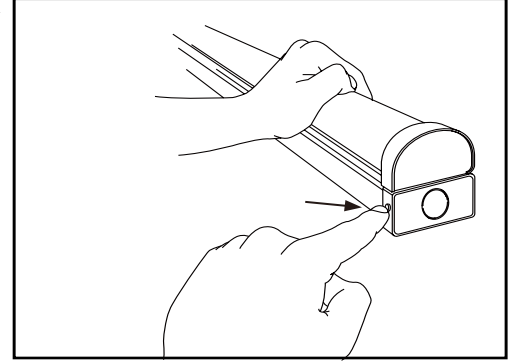

3

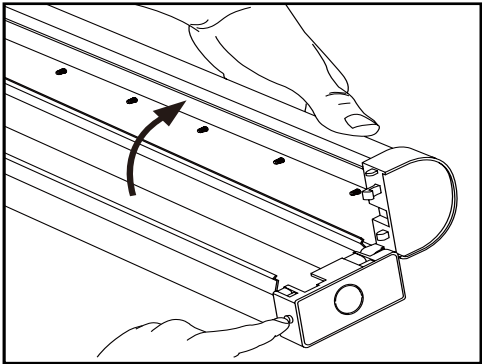

4

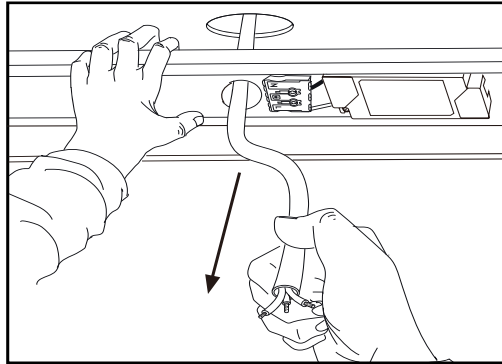

5

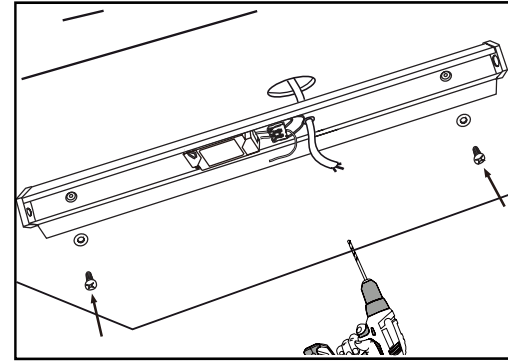

6

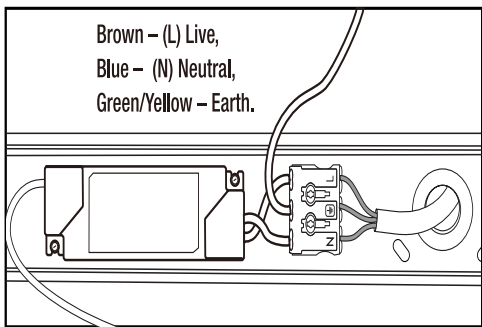

7

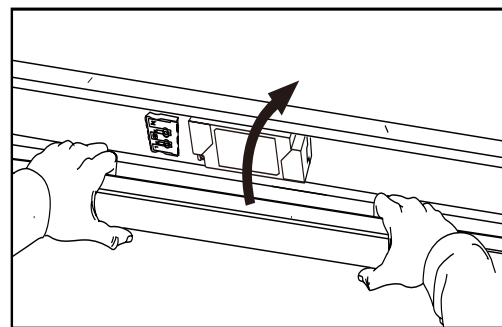

8

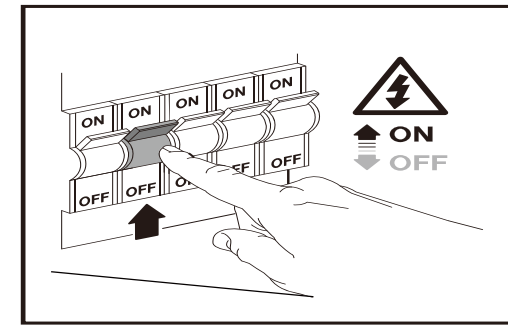

9

## Please Note:

- \*Turn off and isolate the electrical supply before connecting this lighting to the building wires.
- \*Must be installed, or connected by licenced electrician.
- \*The Luminaires are intended for indoor use only.

## Applications:

- Warehouses
- Supermarkets
- Shopping Malls
- Office Buildings
- Workshops
- Car Parks